



E12800
E12830



OPTIMA XR SERIES

21", 27"
Propane Burnishers



Optional
Emissions
Kit Available

Operator and Parts
Manual

TABLE OF CONTENTS

Carbon Monoxide Warning	3
Safety	4
Tank Use and Storage	5
Technical Specifications	5
Operator Preparation.....	5 - 6
Starting and Stopping the Kawasaki Engine.....	6
Belt Tensioning	7
Pad Change Methods	8
Pad Driver Removal	8
Major Assemblies	9
Handle Bar	10 - 11
Lower Handle Support	12 - 13
Regulator Assembly	14 - 15
12V Key Switch Box.....	14 - 15
Kawasaki Engine Assembly.....	16 - 17
Deck Assembly	18 - 19
27" Dust Control Deck Assembly.....	20 - 21
Belt Drive System.....	22 - 23
Pad Drive System.....	24 - 25
Centrifugal Clutch Assembly	26 - 27
Electrical Schematic.....	28 - 29
Engine Maintenance.....	30
Troubleshooting	31
Emissions Warranty	32 - 33
Warranty	36



**WARNING - CARBON MONOXIDE
LETHAL EXHAUST GAS
- MUST READ THIS! -**



Never Run The Engine In A Closed Building Or Confined Area

Exhaust gases contain poisonous carbon monoxide. Carbon monoxide is odorless, colorless, and can cause death if inhaled.

Carbon Monoxide Poisoning Symptoms

Train your employees to know the warning signs of carbon monoxide poisoning.

Mild carbon monoxide poisoning may cause any of the following:
Headache, drowsiness, faintness, poor coordination, nausea, and vomiting.
Turn the engine off and immediately get to fresh air if you have any of these symptoms.

Do not run the machine until it is given an emissions test and repairs made by an authorized distributor.

- Local emissions testing is available at a fork-lift service department.

Moderate or severe carbon monoxide poisoning causes confusion, unconsciousness, chest pain, shortness of breath, and coma. Thus, most victims are not able to move themselves and must be rescued. Severe poisoning is often fatal.

Carbon monoxide is dangerous because a person may not recognize drowsiness as a symptom of poisoning. Consequently, someone with mild poisoning can go to sleep and continue to breathe the carbon monoxide until severe poisoning or death occurs. Some people with long-standing, mild carbon monoxide poisoning caused by furnaces or heaters may mistake their symptoms for other conditions, such as the flu or other viral infections.

Carbon Monoxide Detectors

CO detectors are a must for safe operation of your equipment. Various types are available. A "CO" carbon monoxide detector detects carbon monoxide before it reaches dangerous levels. Detectors are a must for those who run propane powered equipment. The CO Detector is for everyone's protection against Carbon Monoxide Poisoning.

- Carbon Monoxide Detector - Passive
 - Effective for 30 days after package has been opened.
 - Write the date opened on the detector.
 - Mount with self-adhesive strip on the machine handle.
 - Train machine operator to check detector regularly.
 - If the **orange disk changes to gray or black** - your Carbon Monoxide Levels are at a Dangerous Level.
 - If the **orange disk changes to gray or black** you must **turn your buffer off immediately** and return it to your nearest authorized distributor for an emissions test.
 - **Do Not Restart** the machine until the emissions have been checked and corrected.
 - This is for your protection as well as your customers. CO detectors are a must for safe operation and maximum efficiency of your equipment.
 - For replacement CO detectors, contact your distributor. Ask for the **carbon monoxide detector, part # E12426**.
- Carbon Monoxide Detector - battery operated with alarm
 - Available from various sources

SAFETY

Important Safety Information

All LPG (Liquified Petroleum Gas) powered engines, including this engine, produce Carbon Monoxide (CO). It is a **Lethal Poison** that is colorless, odorless, tasteless, and non-irritating gas. You must read “Danger: Lethal Exhaust Gas” information above.

Keep hands, feet, and loose clothing away from all moving parts while the machine is in operation. The exhaust system gets very hot so keep hands, clothing and any items that can burn away from the engine, engine manifold, and muffler.

These machines are tough and durable, however do not abuse the machine. With proper care and maintenance this unit will give you years of trouble free operation.

Carbon Monoxide Safety Information

Engine exhaust gases contain poisonous carbon monoxide. Carbon monoxide is odorless, colorless, tasteless, and can cause death if inhaled. Failure to provide proper venting of CO, failure to properly maintain the engine, or failure to properly train personnel of the dangers and warning signs of carbon monoxide exposure may result in **Serious Injury Or Death** to the operator and others in the area.

- Any equipment with the potential to produce carbon monoxide presents a significant hazard when used indoors. They must be used with great caution. Opening a door or window, or running an exhaust fan will not necessarily supply adequate ventilation. Avoid inhaling exhaust fumes and never run the engine in a closed building or confined area without proper ventilation.
- Do not allow engine to run unattended.
- If you have any indication that the engine is not running properly, immediately shut the machine off and have it checked over and repaired by qualified maintenance personnel.
- Workers should be trained to recognize the hazards of carbon monoxide and the early symptoms of carbon monoxide poisoning.
- A carbon monoxide detector and alarm should be available to alert workers of emissions.
- Have a carbon monoxide detector attached to machine handle or have machine operator wear a carbon monoxide detector. (See carbon monoxide detector page).
- Use only as described in this manual.
- Use only manufacturer’s recommended components.
- Maintenance and repairs must be done by qualified personnel.
- Only trained operators should be allowed to operate propane powered floor machines.
- If the machine is not working properly, have it serviced by an authorized service center.
- Install fuel cylinder in a well ventilated place.
- Be aware of possible leaks of propane gas if odor is present.
- If the machine is stored inside a building, remove the fuel cylinder and store properly outside.
- Secure fuel cylinders when being transported.
- If tank is left attached to the machine then valve should be OFF.
- Never store fuel cylinders in a vehicle, building, or area where they may exposed to high temperature.
- Do not operate the machine with any openings blocked.
- Keep openings free of debris that may reduce airflow.
- Remove fuel cylinder and disconnect battery before servicing.

TANK USE AND STORAGE

Propane Tank Use

We use OPD gas cylinders designed for vapor withdrawal. The fuel lock offs, regulators, and engines are also designed for vapor withdrawal.

- We recommend that you use the OPD (Overflow Protection Device) vapor withdrawal type cylinder. These style tanks have a triangle shaped valve handle.
- Do not overfill - the best gauge is a scale - never allow tank to weigh over **36 pounds** for an aluminum tank and **43 pounds** for a steel tank.
- Connect fuel cylinder to machine in a well ventilated place.
- Be aware of possible leaks of propane gas if odor is present.
- Use propane tanks designed for vertical use only.

Propane Tank Storage

- Store tanks outside in a well-ventilated area.
- Never store fuel cylinders in a vehicle, building, or area where they may exposed to high temperature.
- If the machine is stored inside a building, remove the fuel cylinder and store properly outside.
- Secure fuel cylinders when being transported.
- If tank is left attached to the machine then valve should be OFF.
- Store tanks in the upright position (valves up).
- Be aware of possible leaks of propane gas if odor is present.
- New tanks must be purged of air at first fill.

TECHNICAL SPECIFICATIONS

TECHNICAL DESCRIPTION	MEASUREMENT UNIT	Optima XR 21"	Optima XR 27"
Working Width	in	21	27
Length	in	49	56
Width	in	22.5	29.5
Height	in	37.5	37.5
Weight (without propane tank)	lb	211	228
Engine Speed	RPM	2800	
Pad Speed	RPM	1825	1450
Electrical System	V	12 DC	
Sound Level	dB(A)	< 85	

OPERATION PREPERATION

Before Starting the Machine

Read the Owner’s Manual and the Engine Operation Manual.

Your machine is shipped ready for operation; however there is no fuel in the tank. When having the tank filled, you must make sure the tank is never over-filled.

- The best way to do this is to tell the filling station to weigh the tank full. On an aluminum tank, it should weigh no more than **36 pounds** and on a steel tank no more than **43 pounds**. (See more information at “Tank Storage and Maintenance” page.)

OPERATOR PREPARATION

Adjust the handle for comfortable operation. Remove detent pins from the handle, and adjust to the hole alignment that gives the most comfortable height. Replace detent pins. Tighten nuts and bolts if needed.

Make sure pad is not torn, pad is well attached and centering device is tightened.

Check Oil Level: Starting the engine without the proper amount of oil will cause severe engine damage. Always keep the engine oil level between the full and add marks on the dipstick. Do not loosen oil fill cap or remove dipstick while engine is running.

- Park your burnisher on a level surface.
- Turn the oil fill cap counter clockwise and then lift from the fill tube.
- Wipe the dip stick clean and push it back into the oil fill tube until the cap seats and then withdraw it to check: the oil level. (Do not screw cap on to check oil). Add if necessary. If the oil level is low, add API Class SM oil having a SAE viscosity grade appropriate for the expected temperatures as indicated in the Operators Manual (Usually a HD30 or 10W30).
- Important Note: **Do Not Overfill**
- Replace oil cap.

Inspect fuel hoses and fittings for wear and leaks. Have all worn hoses and leaks repaired before operating.

Look and listen for exhaust leaks. Have all leaks repaired before operating.

Check the carburetor filter and air filter for debris. Clean and replace if necessary.

Connect fuel hose to tank by screwing the hose fitting to tank. You must tighten all the way down to make fuel connection. Turn tank knob slowly until you hear the flow of fuel into fuel system.

STARTING AND STOPPING THE KAWASAKI ENGINE

Starting The Kawasaki Engine

The Kawasaki engine is equipped with a 12 volt starter and a key switch start.

1. Place propane tank into handle assembly and close propane tank strap clamp to secure tank.
2. Attach propane hose coupling and fully tighten.
3. Tilt machine back so that pad is off the floor.
4. Open propane tank valve (turn counterclockwise) and check for any leaks.
5. Put throttle cable into the "slow" position. (Note: If starting is difficult, you can place throttle in the fast" position).
6. Turn the ignition - start switch to the "start" position and hold it there until the engine starts. Do not crank for more than 20 seconds at a time and wait at least one minute between tries when cranking. See troubleshooting guide if the engine does not start after several tries.
7. After engine starts, set throttle to a slow operating speed until the motor warms up. Engine speed may be increased after 3 to 5 minutes.
8. Check for frost on the regulator and fuel line. Frost will indicate that the machine is drawing liquid propane from an overfilled or incorrect tank.
9. If frost is present on the regulator or fuel line, turn off the machine and have the tank inspected by a certified technician.

Stopping The Kawasaki Engine

1. Turn propane tank valve to the closed position (turn clockwise) and allow the engine to continue running until it runs out of fuel.
2. Turn key to the off position. (In an emergency, turn the key to the off position. Backfiring may occur when using this method).

BELT TENSIONING

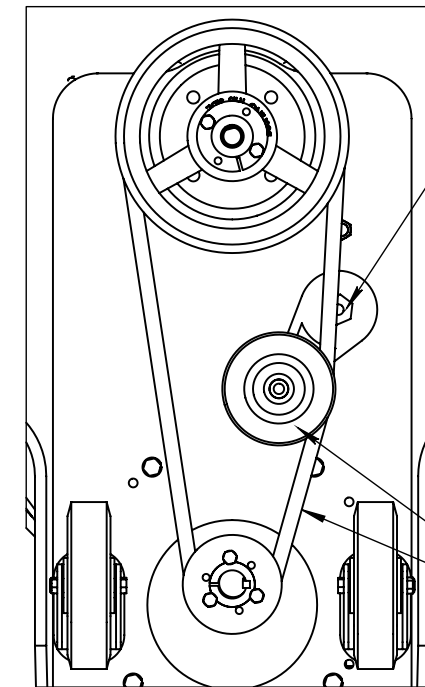

Use 15/16" socket with extension to tighten tensioner in direction of arrow.

Test tension by pushing or pulling on belt or belt tensioner. With proper belt tension the pulley on the belt tensioner should only move about 1".

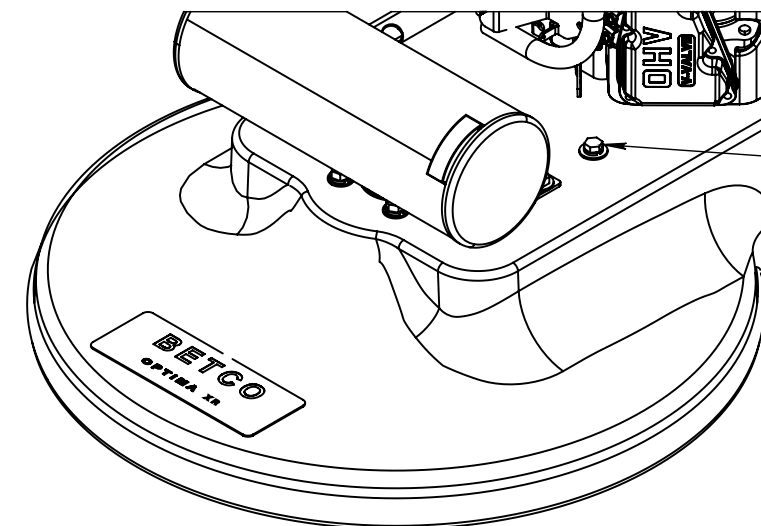

Use 9/16" wrench to tighten tensioner bolt.

1. Tilt Machine back onto rear caster or tilt machine onto its side.
2. Remove the pad driver using 3/4" open ended wrench. (See pad changing & pad driver removal section)
3. On top of the deck use a 9/16" wrench to loosen the belt tensioner bolt.
4. Using a 15/16" socket and extension, fully tighten the belt tensioner from the underside of the deck.
5. Back off fully tightened belt tensioner about 10-15 degrees about 1 mark or about 2 inches at the end of the socket handle. (Note: There are 5 marks on the side of the tensioner. Each mark is equal to about 15 degrees and this leaves about 60 degrees of tightness.)
6. While holding the belt tensioner in position tighten the tensioner bolt on top of the deck. **TIGHTEN SECURELY!**
7. Hand test the tensioner by pushing and pulling on the tensioner. The belt should be tight and the arm should move about 10-15 degrees about 1".

PAD CHANGE METHODS

Caution: Muffler May Be Hot!

1. Tilt the machine back on its caster.
2. Unscrew the pad center threaded hold.
3. Remove the pad from the pad driver.
4. Get new, correct size pad for burnisher.
5. Center new pad on pad driver.
6. Screw in the pad center threaded hold until tight.
7. Place machine upright.
8. Set front of machine on floor to ensure pad driver grips pad before starting.

1. Close valve and remove propane tank from the machine.
2. Lay the machine sideways on the ground to the operators right hand side ensuring that the regulator and oil fill tube are facing upward.
3. Unscrew the pad center threaded hold.
4. Remove the pad from the pad driver.
5. Get new, correct size pad for burnisher.
6. Center new pad on pad driver.
7. Screw in the pad center threaded hold until tight.
8. Place machine upright.
9. Set front of machine on floor to ensure pad driver grips pad before starting.

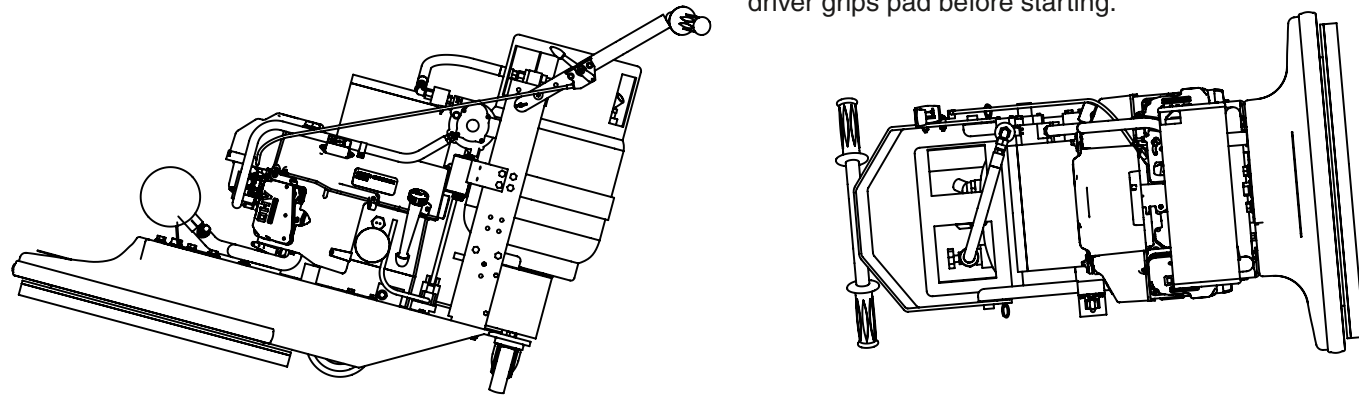

PAD DRIVER REMOVAL

Note: Muffler is removed to show pad driver shaft.

Spin the pad driver the direction of the arrow to loosen.

Use a 3/4" open end wrench as shown to hold pad drive shaft while spinning the pad driver.

When screwing on the pad driver spin pad driver in opposite direction of arrow. Snug pad driver without wrench. When the machine is started the contact between the floor and the pad will tighten the pad driver completely.

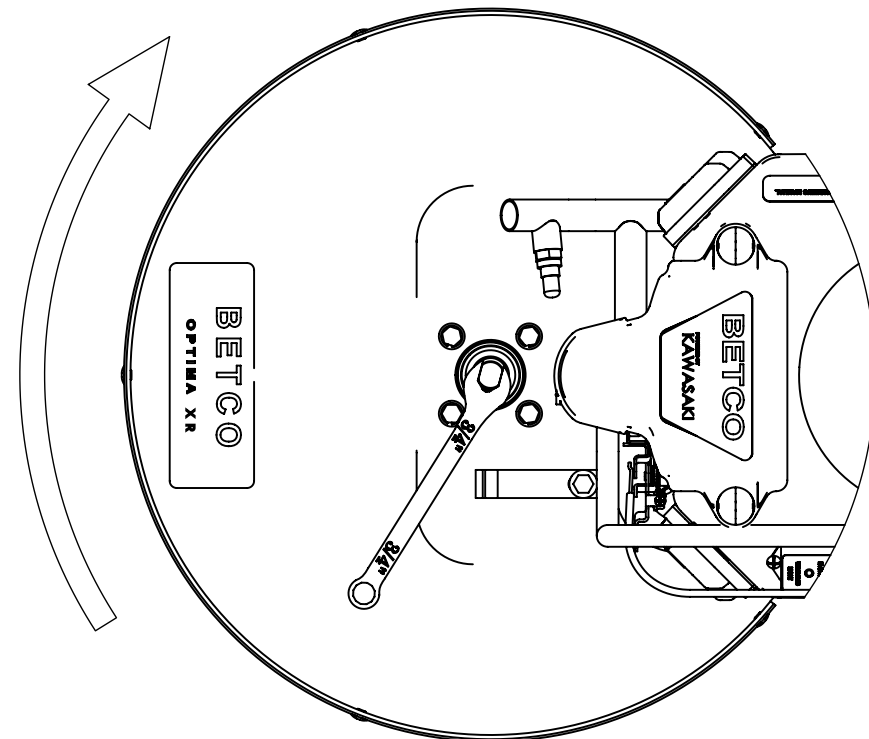

MAJOR ASSEMBLIES

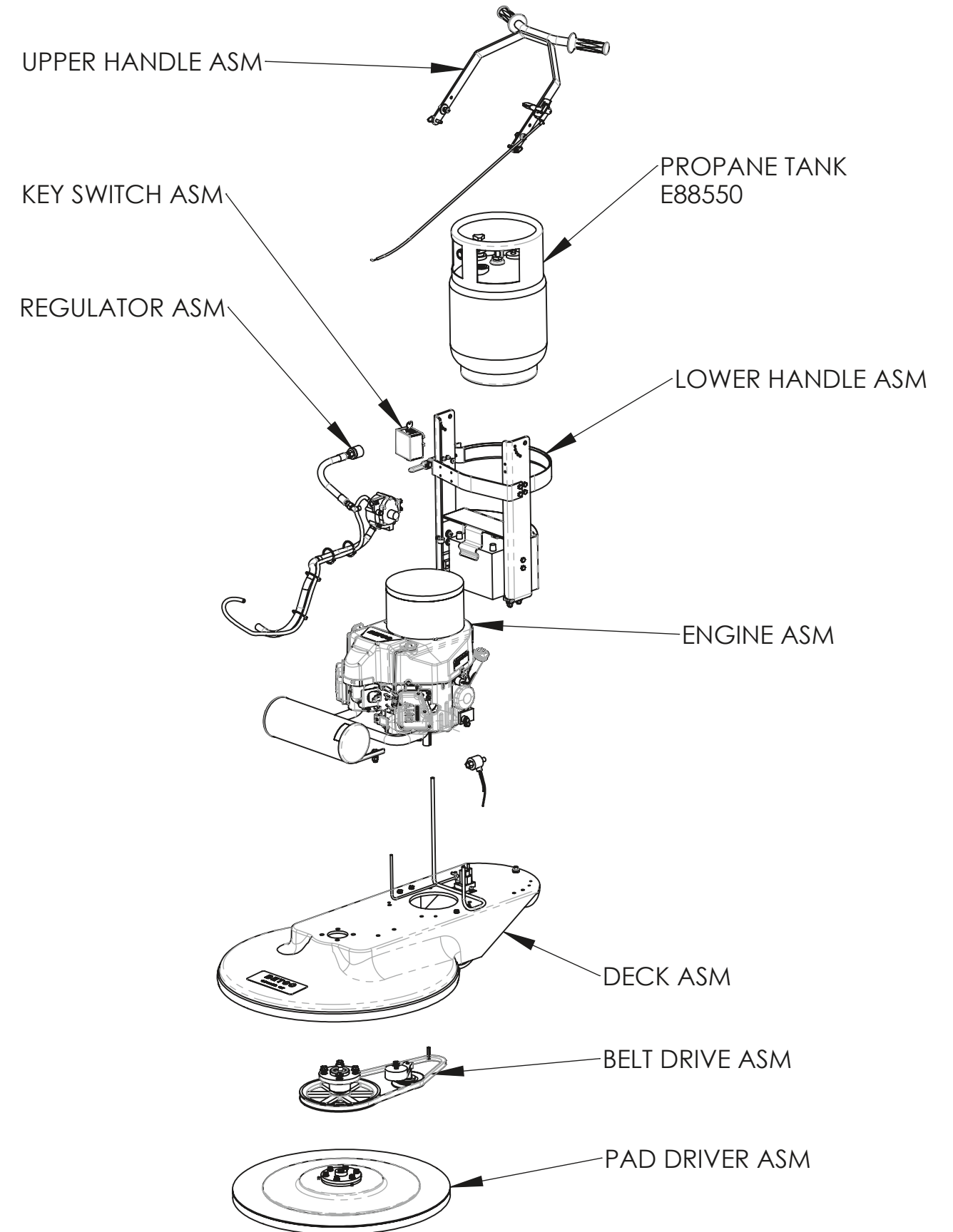

HANDLE BAR

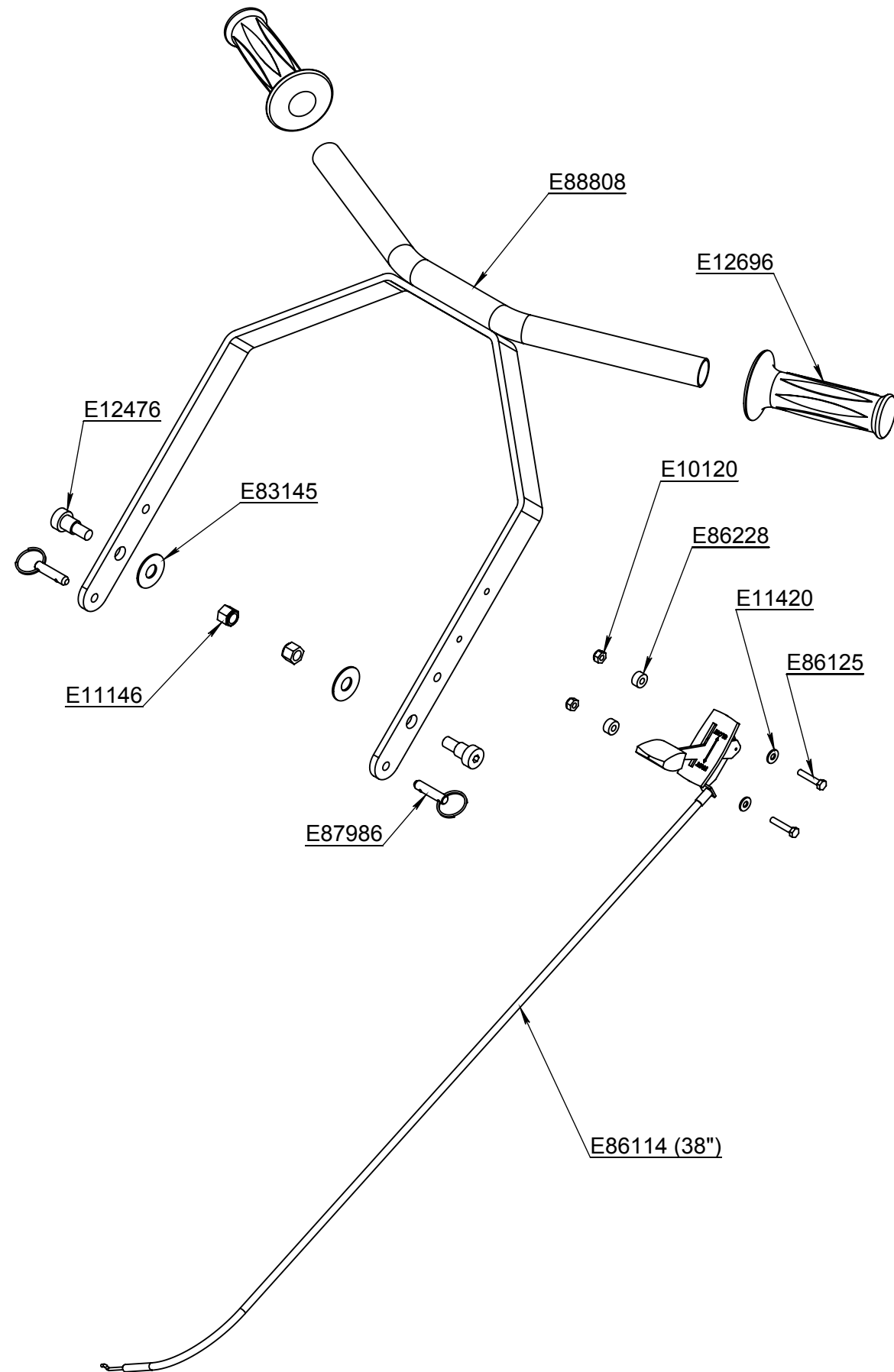

PART NUMBER	Description	QTY.
E10120	Nut, #10-32, Nylon Lock, Grade 5, Zinc	2
E11146	Nut, 3/8"-16, Nylon Lock, Grade 5, Zinc	2
E11420	Washer, #10 SAE, Zinc	2
E12476	Screw, Shoulder 1/2" x 1/2" Socket Head	2
E12696	Hand Grip	2
E83145	Washer, Nylon 1/2" ID X 1.25" OD	2
E86114	Kawasaki Throttle Cable 38" L	1
E86125	Screw, #10-32 x 1.000 Hex Head, Zinc	2
E86228	Spacer, #10 ID x 1/2" OD x 1/4" Long, Black Nylon	2
E87986	Pin, 5/16" x 3/4" Detent with Ring	2
E88808	Handle Bar Weldment	1

Note: Not available for purchase assembled.

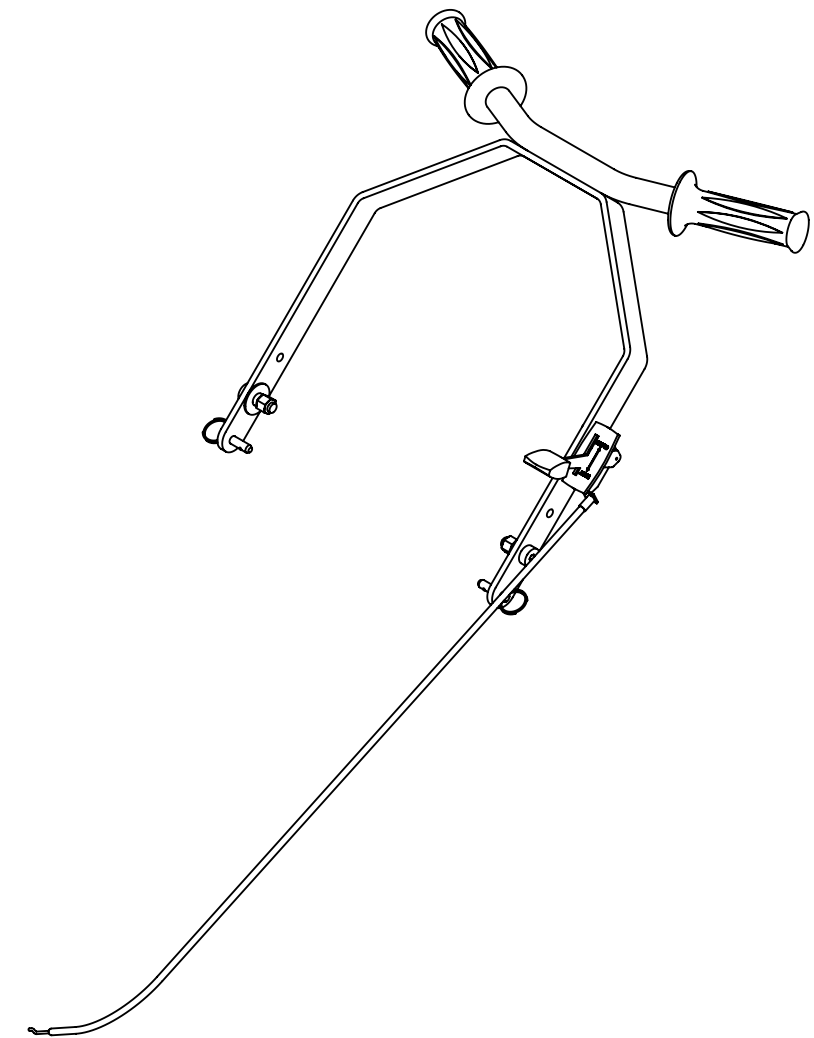

LOWER HANDLE SUPPORT

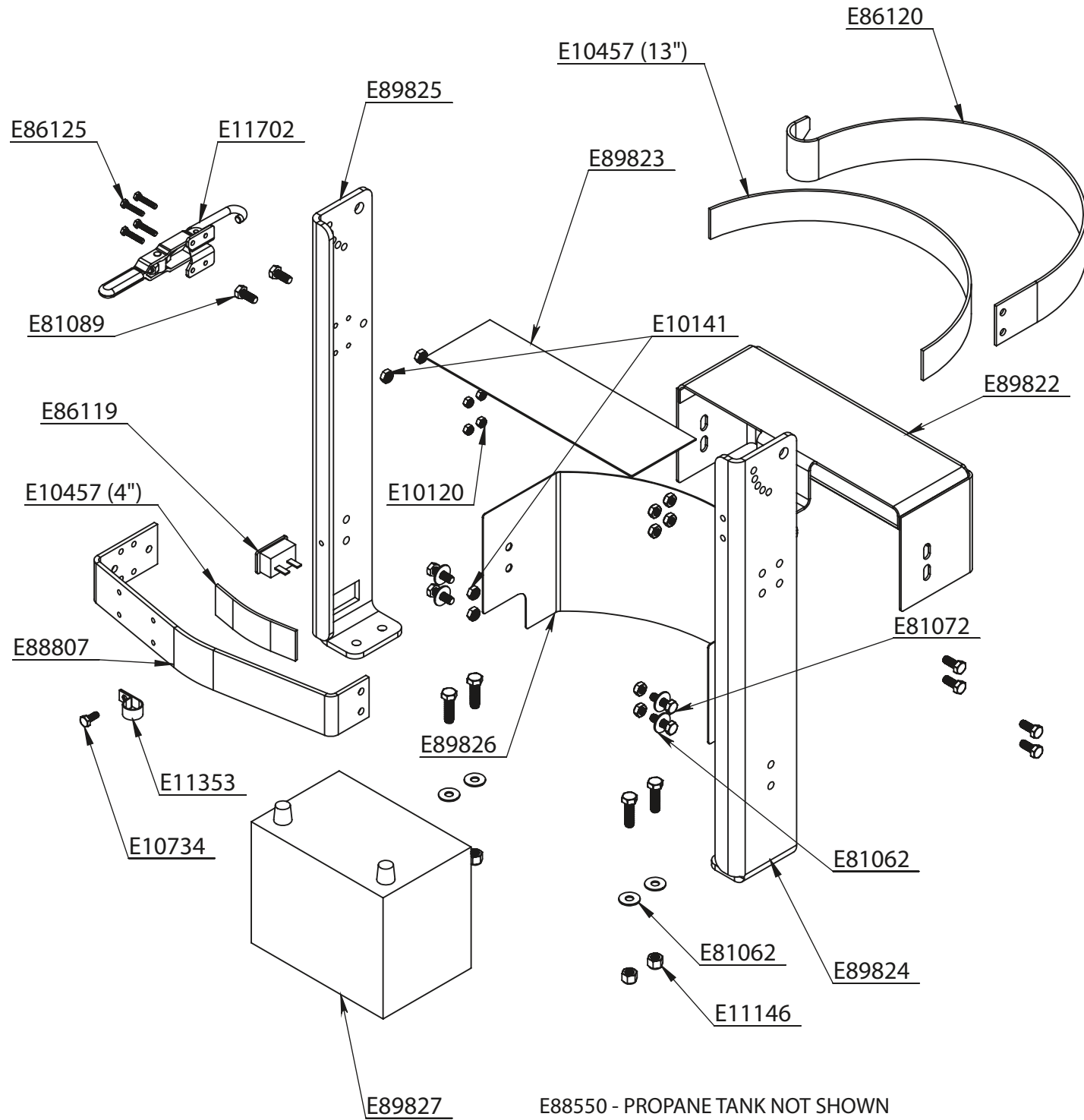

PART NUMBER	DESCRIPTION	QUANTITY
E10120	NYLOC HEX NUT 10-32	4
E10141	NYLOC HEX JAM NUT 0.3125-18 ZINC	10
E10457	FELT, 1.500 W x 0.125 THK, ADHESIVE BACKED	2
E10734	HEX HEAD BOLT 1/4-20 x 5/8 LG	1
E11146	NYLOC HEX NUT 3/8-16, ZINC	4
E11353	TUBE CLAMP 3/4"	1
E11702	PROPANE TANK STRAP CLAMP	1
E81062	FLAT WASHER 5/16 USS, ZINC	8
E81072	HEX HEAD SCREW 5/16-18 x 1.00 LG	4
E81089	HEX HEAD BOLT 5/16-18 x 3/4 LG	6
E83629	HEX HEAD BOLT 3/8-16 x 1-1/4 LG	4
E86119	HOUR METER	1
E86120	PROPANE TANK STRAP BACK	1
E86125	HEX HEAD BOLT, 10-32 x 1.00 LG	4
E88807	PROPANE TANK STRAP FRONT	1
E89822	BATTERY CLAMP AND PROPANE SUPPORT	1
E89823	RUBBER PROPANE TANK SHELF PAD	1
E89824	LOWER HANDLE LEG LEFT	1
E89825	LOWER HANDLE LEG RIGHT	1
E89826	BATTERY COVER	1
E89827	BATTERY U1 12 VOLT	1
E88550	Propane Tank, Steel, 20#, OPD	1

Note: Not available for purchase assembled.

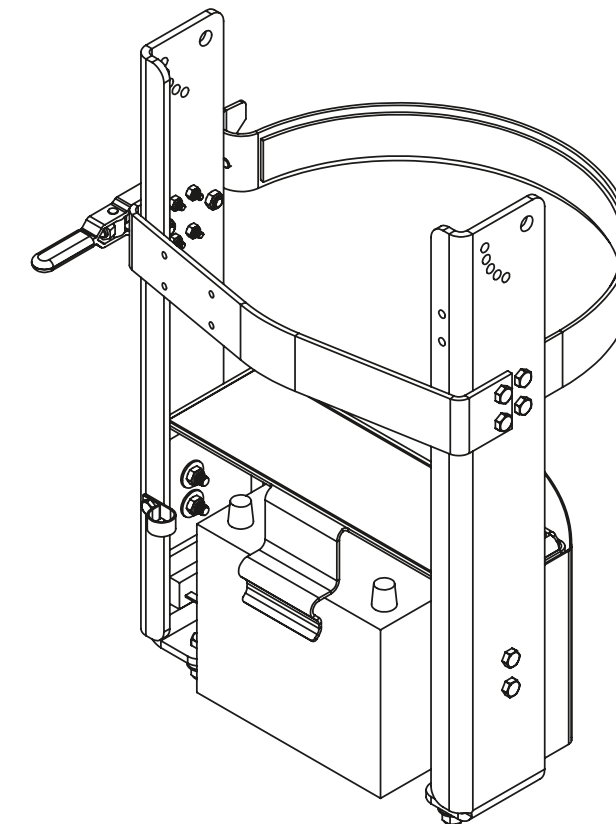

REGULATOR ASSEMBLY

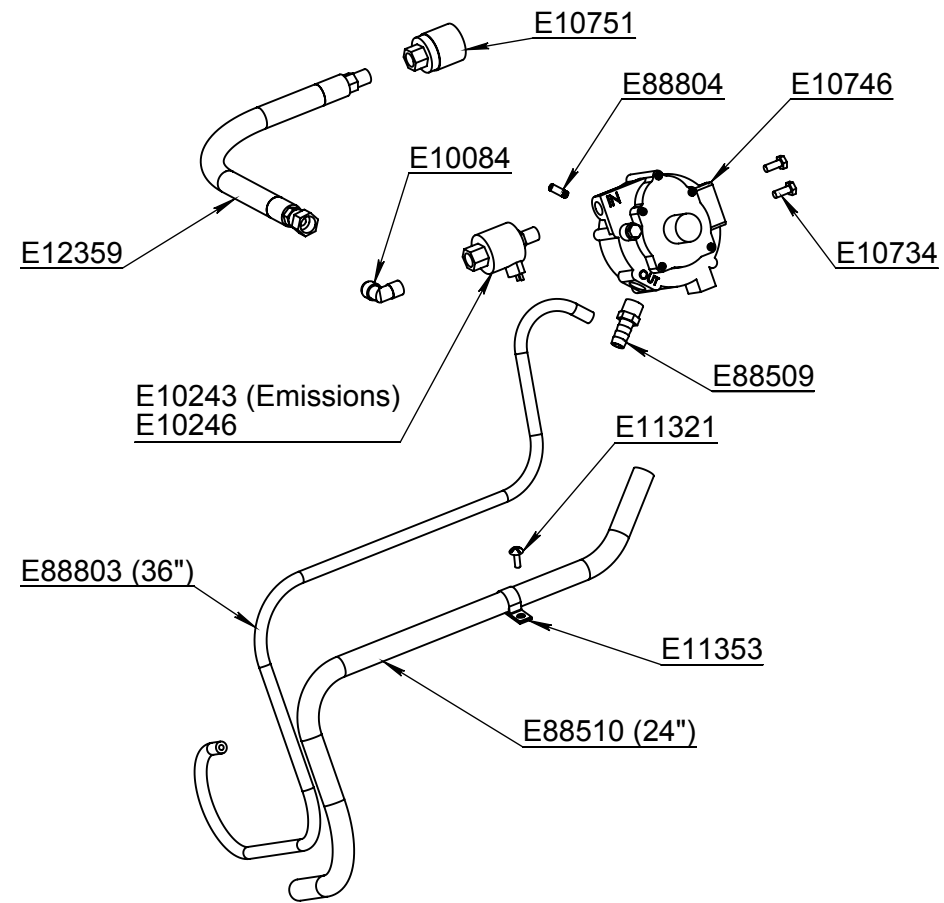

PART NUMBER	Description	QTY.
E10084	Fitting, 3/8 MJIC x 3/8 MNPT, 90 Elbow, Brass	1
E10243	In Line Fuel Shut Off Valve Model 152 (With Emissions)	1
E10246	In Line Fuel Shut Off Valve Model 151	1
E10734	Screw, 1/4"-20 x 0.625 Hex Head, Grade 5, Zinc	2
E10746	Fuel Regulator Model 60E	1
E10751	Propane Tank Coupling 7141F	1
E11321	Screw #10 x 5/8" Sheet Metal, Pan Head, Phillips, Black	1
E11353	Tube Clamp 3/4" (COV-1309)	1
E12359	Propane Tank Hose 1/4" MNPT - 3/8" MJIC 16.50" L	1
E88509	Fitting, Hose Barb 3/8" MNPT x 1/2" Barb, Brass	1
E88510	1/2" ID Braided Gasoline Fuel Hose (24")	1
E88803	Hose, 3/16" ID Vacuum	1
E88804	Fitting, 1/4"-28 Thread, 1/4" OD, 0.046 Wall, 0.700 L, Brass	1

Note: Not available for purchase assembled.

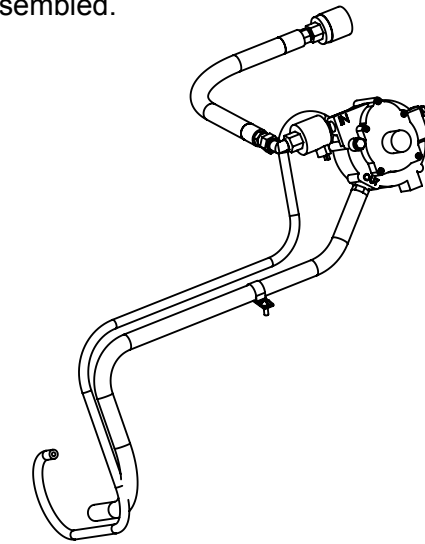

12V KEY SWITCH BOX

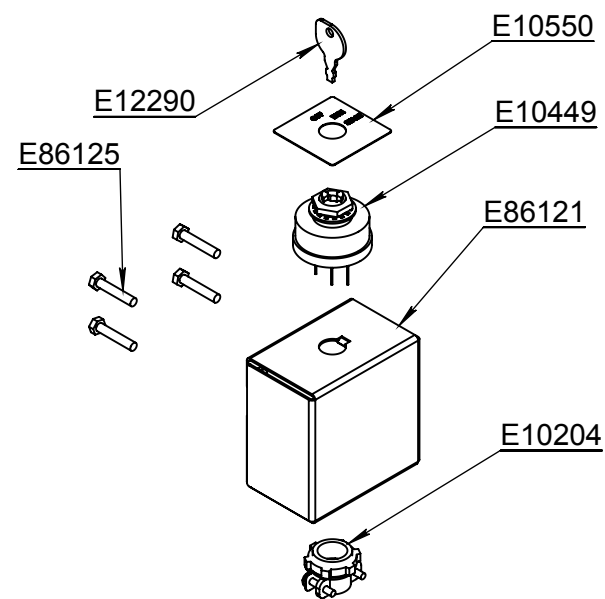

PART NUMBER	Description	QTY.
E10204	Wire Clamp, 3/8" Romex Connector	1
E10449	5 Wire Keyed Ignition Switch	1
E10550	Decal, OFF/ON/START	1
E12290	Ignition Switch Key	1
E86121	Key Switch Box	1
E86125	Screw, #10-32 x 1.000 Hex Head, Zinc	4

Note: Not available for purchase assembled.

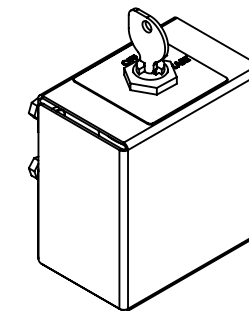

KAWASAKI ENGINE ASSEMBLY

- E10242 - Emission Kit (E10248 & E10249)
- E10245 - Bung Plug M18 x 1.5mm
- E10337 - Valve Oil Seal
- E10544 - Decal, Clutch
- E12525 - Drive Shaft Oil Seal
- E85461 - Oil Drain Hose ASM
- E88326 - Spark Plug
- E88327 - Ignition Coil ASM
- E88328 - Air Intake Manifold
- E88468 - Head Gasket
- E88469 - Cylinder 1 Head ASM
- E88470 - Cylinder 2 Head ASM
- E88471 - Valve Cover Gasket
- E88472 - Intake Valve
- E88473 - Exhaust Valve
- E88476 - Dipstick Tube O-Ring
- E88511 - Voltage Regulator
- EP50270 - LP Ready Kawasaki Engine ASM With Emission Kit (E10242)
- EP50271 - LP Ready Kawasaki Engine ASM

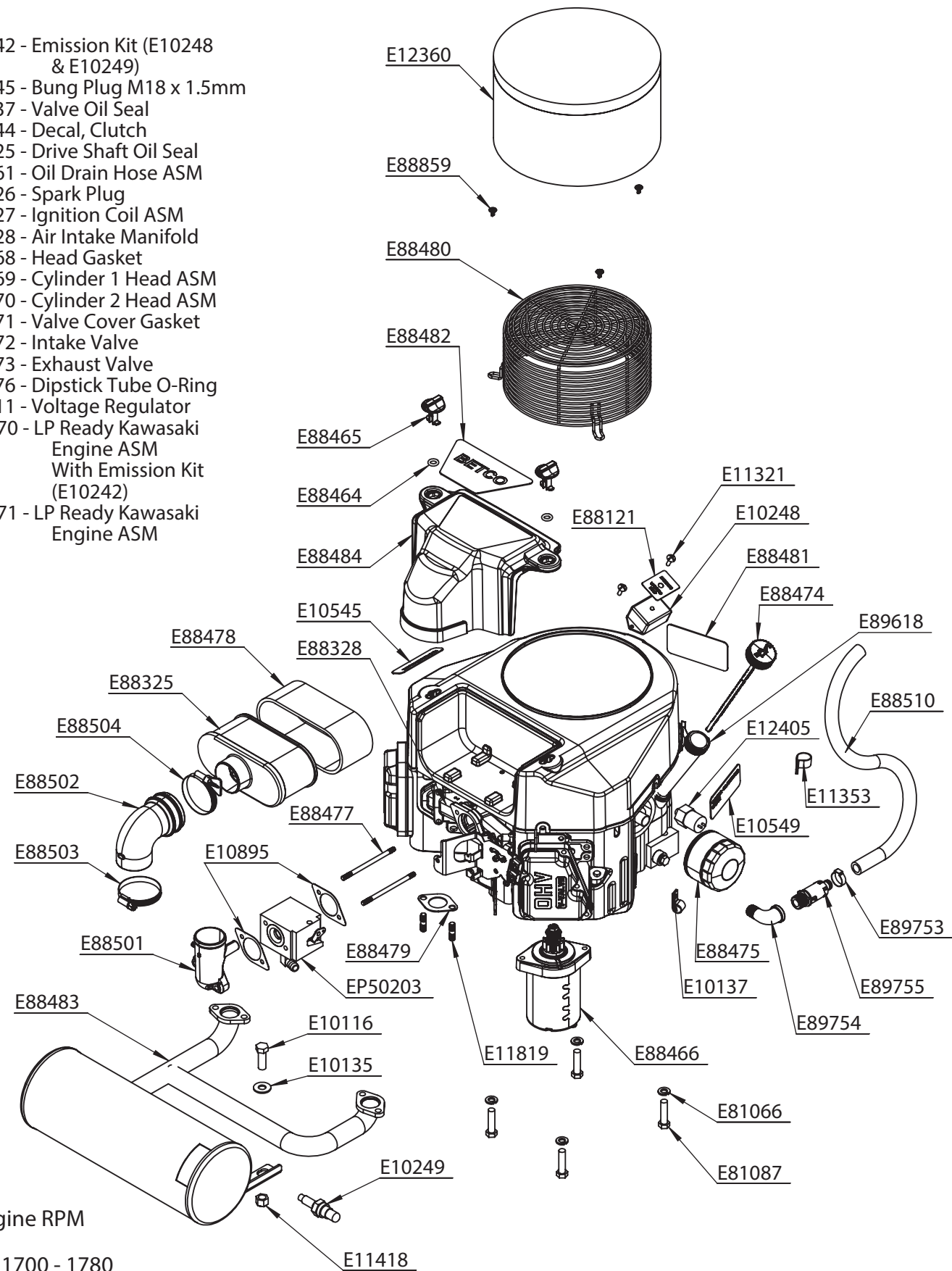

Engine RPM

Idle = 1700 - 1780
Full Throttle = 2800

PART NUMBER	Description	QTY.
E10116	Screw, 7/16"-14 x 1.250 Hex Head, Grade 5, Zinc	1
E10135	Washer, 3/8" USS, Zinc	1
E10137	Clamp, Tube 1/2" (COV-0909)	1
E10242	Emissions Kit (E10248, E10249)	1
E10245	Bung Plug M18 x 1.5mm	1
E10248	O2 Sensor Electrical Control Box	1
E10249	O2 Sensor	1
E10337	Valve Oil Seal	4
E10544	Decal, Clutch	1
E10549	Decal, Caution Oil Pressure Switch	1
E10895	Gasket, Carburetor to Air-Fuel Hub	2
E11321	Screw #10 x 5/8" Sheet Metal, Pan Head, Phillips, Black	2
E11353	TUBE CLAMP 3/4" (COV-1309)	1
E11418	Nut, 7/16"-14, Nylon Lock, Grade 5, Zinc	1
E11819	Stud, 8mm x 18mm L	4
E12360	Cooling Air Intake Filter	1
E12405	Oil Pressure Switch	1
E12426	CO Detector Badge	1
E12525	Drive Shaft Oil Seal	1
E81066	Washer, 3/8" Split Lock, Zinc	4
E81087	Screw, 3/8"-16 x 1.500 Hex Head, Grade 5, Zinc	4
E85461	Oil Drain Hose Accessory	1
E88121	Decal, Emissions Warning Light	1
E88325	Air Intake Filter Paper	1
E88326	Spark Plug	2
E88327	Ignition Coil ASM	2
E88328	Air/Fuel Intake Manifold	1
E88464	O-Ring 12.5mm ID x 3.4mm T	2
E88465	Air Filter Thumb Nut	2
E88466	12V Starter	1
E88468	Head Gasket	2
E88469	Cylinder 1 Head ASM	1
E88470	Cylinder 2 Head ASM	1
E88471	Valve Cover Gasket	2
E88472	Intake Valve	2
E88473	Exhaust Valve	2
E88474	Oil Dipstick	1
E88475	Oil Filter	1
E88476	O-Ring	1
E88477	Stud, 6mm x 95mm L	2
E88478	Air Intake Filter Foam	1
E88479	Muffler Gasket	2
E88480	Cooling Air Intake Guard	1
E88481	Decal, Emissions	1
E88482	Decal, Air Filter Cover	1
E88483	Muffler, Catalytic, & Manifold Kawasaki FS481V	1
E88484	Air Filter Cover	1
E88501	Carburetor Intake Neck	1
E88502	Air Intake Elbow	1
E88503	Air Intake Elbow to Neck Clamp	1
E88504	Air Intake Elbow to Filter Clamp	1
E88510	1/2" ID BRAIDED GASOLINE FUEL HOSE	1
E88511	Voltage Regulator	1
E88859	Rivet, Push, Cooling Air Intake Guard, FS481V ASM	3
EP89618	Oil Fill Tube	1
E89753	1/2" OETIKER CLAMP	1
E89754	3/8-18 STREET ELBOW	1
E89755	Oil Drain Valve 0.375 MNPT To Barb 0.5	1
EP50270	LP Ready Kawasaki Engine Assembly With Emission Kit (E10242)	1
EP50271	LP Ready Kawasaki Engine Assembly	1
EP50203	Carburetor, LP Gas FS481V	1

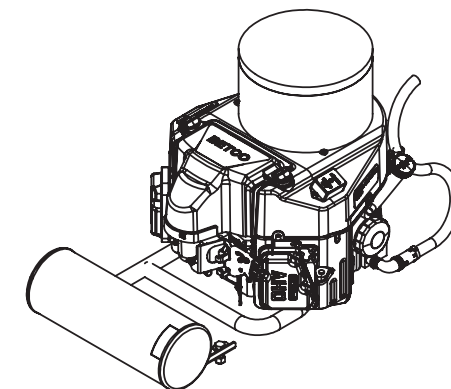

DECK ASSEMBLY

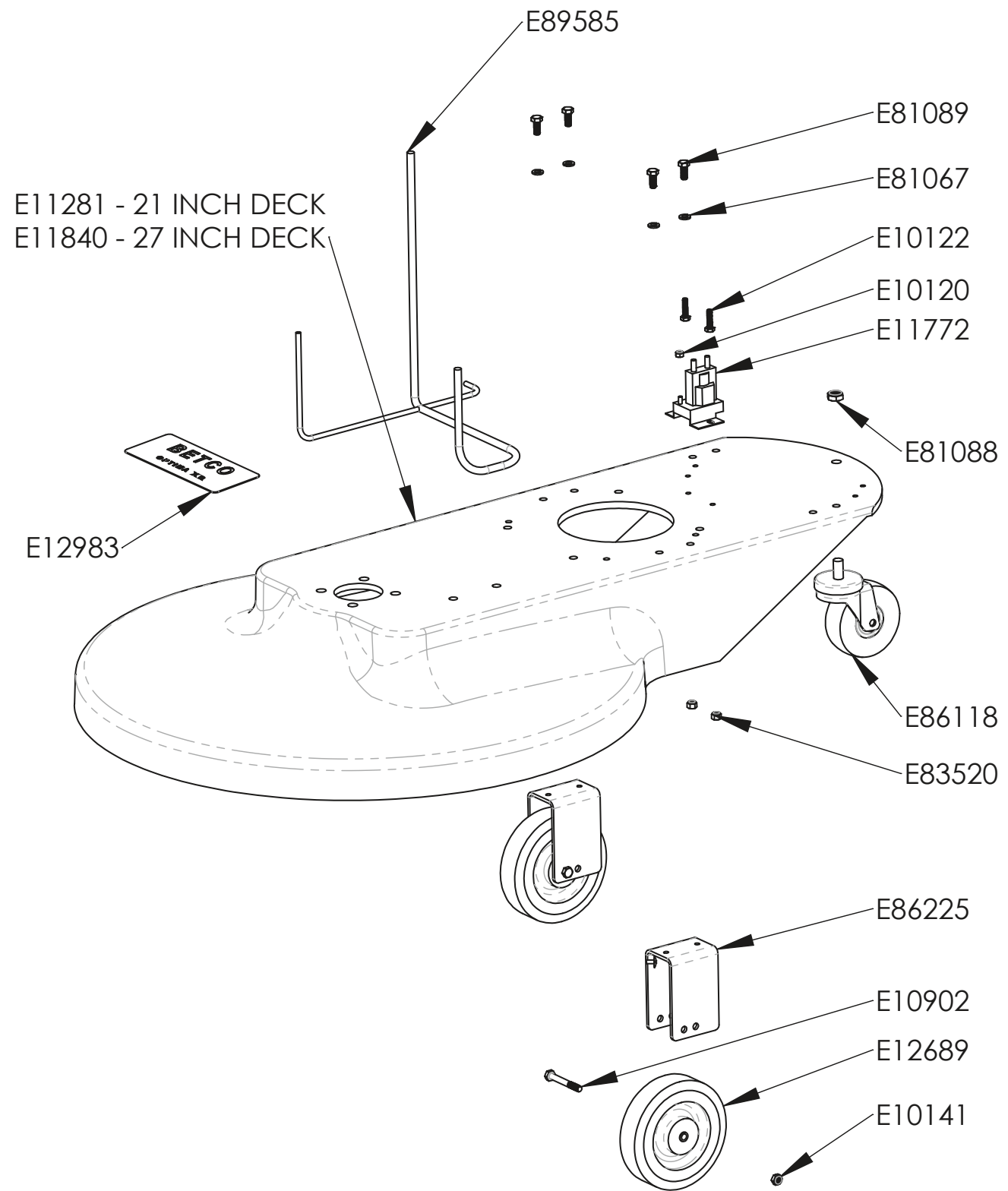

PART NUMBER	DESCRIPTION	QTY.
E10120	NYLOC HEX NUT 10-32	1
E10122	HEX HEAD BOLT 1/4-20 x 1.00 LG	2
E10141	NYLOC HEX JAM NUT 0.3125-18 ZINC	2
E10902	HEX HEAD BOLT 5/16-18 x 2-1/2 LG ZINC	2
E11772	SOLENIOD 12 VDC	1
E11840	DECK 27 INCH BURNISHER	1
E12689	WHEEL 6 INCH DIA	2
E12983	DECAL	1
E81067	LOCK WASHER 5/16	4
E81088	NYLOC JAM NUT 1/2-13	1
E81089	HEX HEAD BOLT 5/16-18 x 3/4 LG	4
E83520	NYLOC HEX NUT 1/4-20	2
E86118	3 INCH SWIVEL CASTER 1/2-13 x 1.00 LG STUD	1
E86225	WHEEL BRACKET 3 INCH	2
E89585	WIRE HARNESS	1

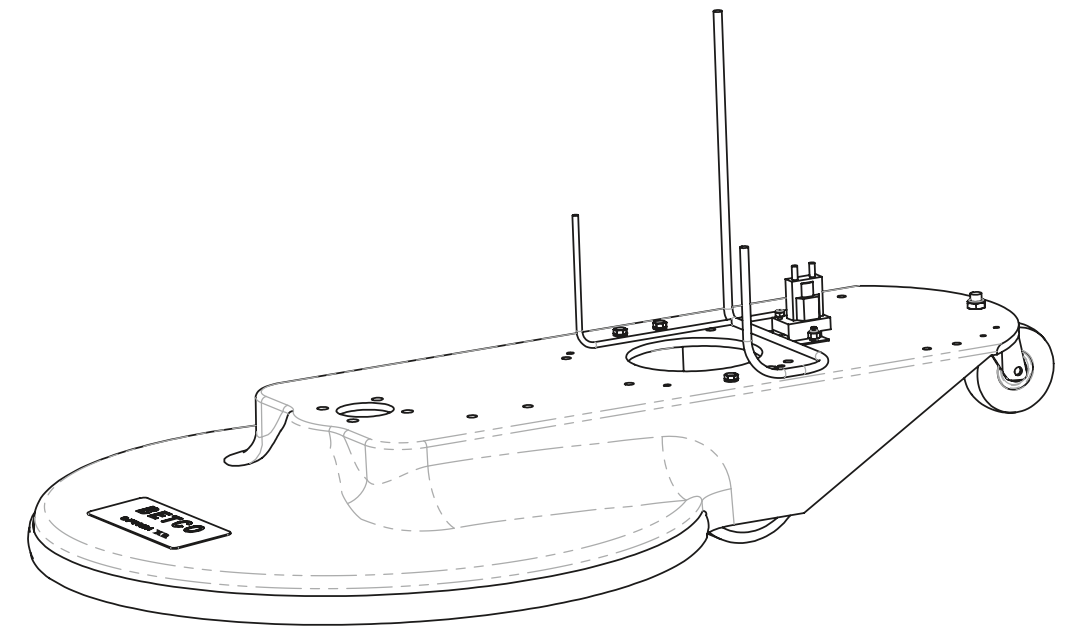

27" DUST CONTROL DECK ASSEMBLY

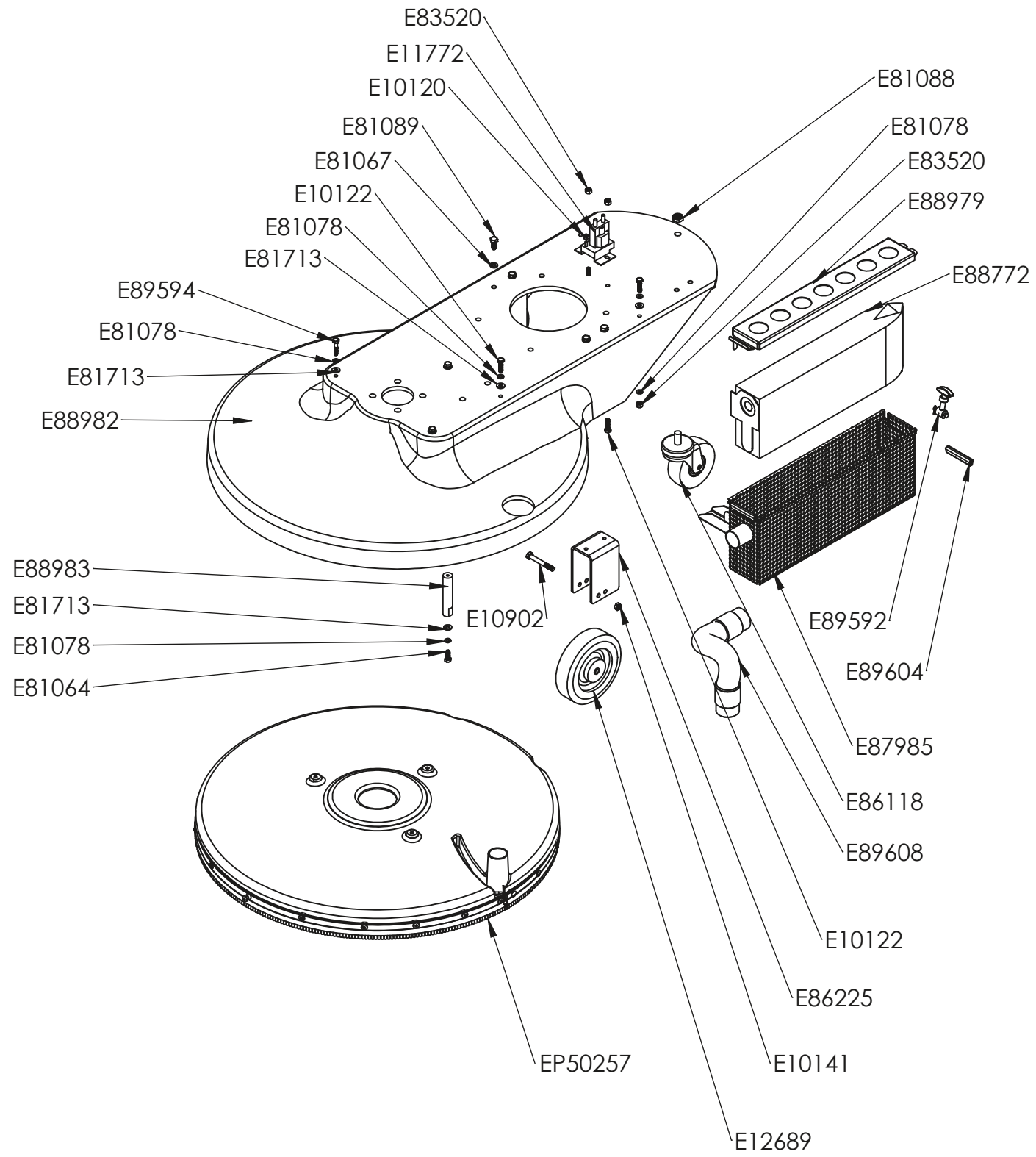

PART NUMBER	DESCRIPTION	QTY.
E10120	NYLOC HEX NUT 10-32	1
E10122	HEX HEAD BOLT 1/4-20 x 1.00 LG	4
E10141	NYLOC HEX JAM NUT 0.3125-18 ZINC	2
E10902	HEX HEAD BOLT 5/16-18 x 2-1/2 LG ZINC	2
E11772	SOLENIOD 12 VDC	1
E12689	WHEEL 6 INCH DIA	2
E81064	HEX BOLT 1/4-20 x 0.75 LG ZINC	3
E81067	LOCK WASHER 5/16	4
E81078	LOCK WASHER, 0.250	10
E81088	NYLOC JAM NUT 1/2-13	1
E81089	HEX HEAD BOLT 5/16-18 x 3/4 LG	4
E81713	FLAT WASHER 1/4	8
E83520	NYLOC HEX NUT 1/4-20	4
E86118	3 INCH SWIVEL CASTER 1/2-13 x 1.00 LG STUD	1
E86225	WHEEL BRACKET 3 INCH	2
E87985	FILTER BAG HOLDER WELDMENT	1
E88772	FILTER BAG	1
E88979	BAG HOLDER COVER	1
E88982	DECK 27 INCH DUST CONTROL	1
E88983	STANDOFF	3
E89592	DRAW LATCH	1
E89594	HEX BOLT 1/4-20 x 1.25 LG ZINC	3
E89604	EDGING	2
E89608	HOSE ASSEMBLY	1
EP50257	DUST SHROUD ASSEMBLY, 27"	1

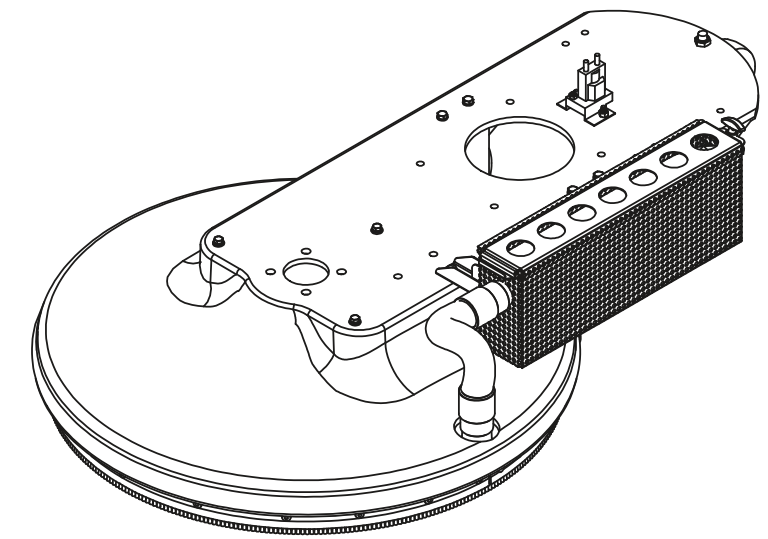

BELT DRIVE SYSTEM

E12609 -- place between E12709 & aluminum deck at this bolt location.

E10135 -- place between E12709 and aluminum deck at this bolt location.

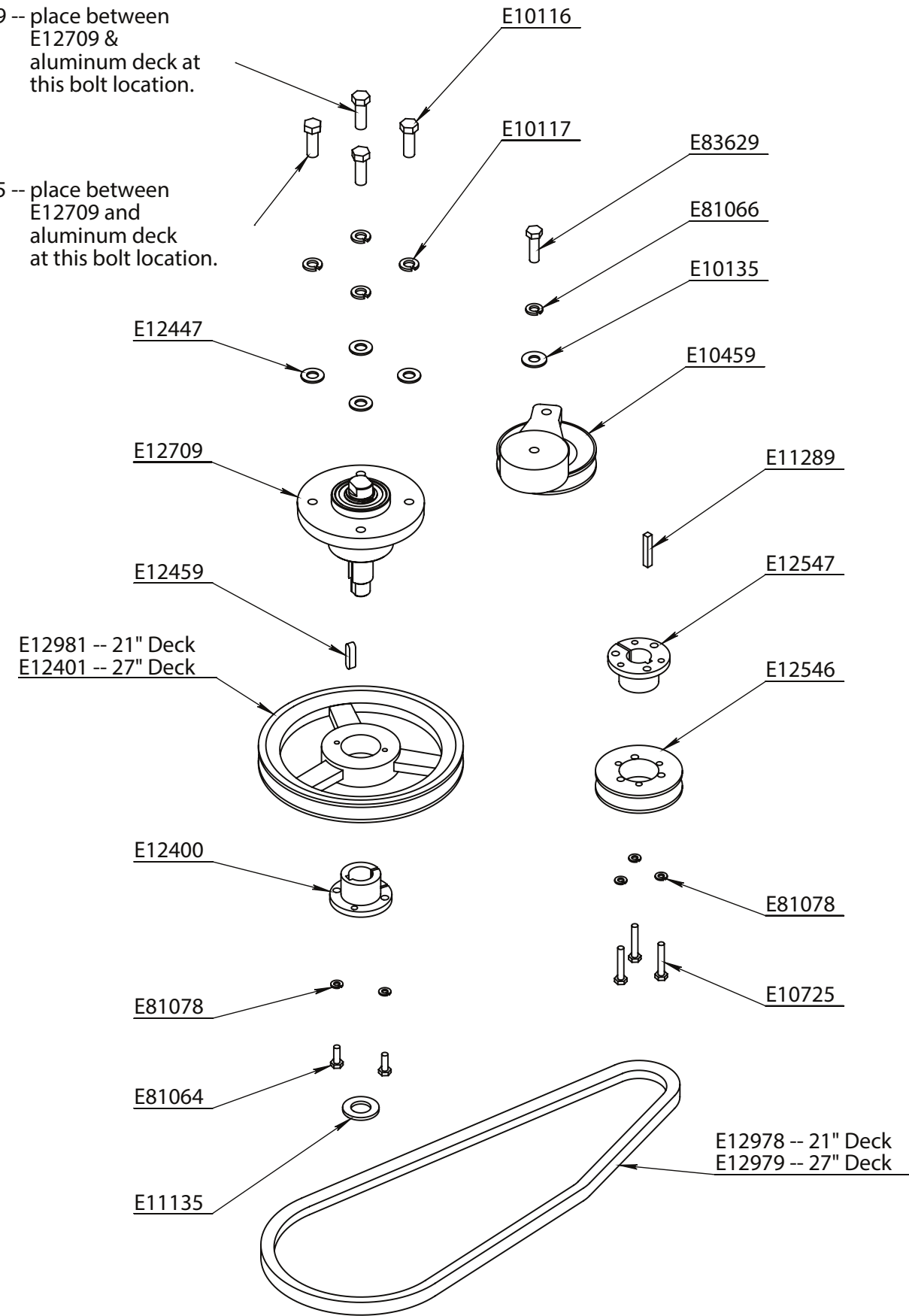

PART NUMBER	Description	QTY.
E10116	Screw, 7/16"-14 x 1.250 Hex Head, Grade 5, Zinc	4
E10117	Washer, 7/16" Split Lock, Zinc	4
E10135	Washer, 3/8" USS, Zinc	1
E10459	Belt Tensioner	1
E10725	Screw, 1/4"-20 x 1.500 Hex Head, Grade 5, Zinc	3
E11135	Washer, 3/4" SAE, Zinc	1
E11289	Key 1/4" x 1/4" x 1.500"	1
E12400	Bushing, QT 25mm Taper Lock	1
E12401	Pulley BK75H - 7.50 OD	1
E12447	Washer, 7/16" SAE, Zinc	4
E12459	Key 8mm x 7mm x 30mm	1
E12546	Engine Pulley 1B34SH - 3.75 OD	1
E12547	Bushing, SH 1.00" QD Taper Lock	1
E12609	Shim	1
E12709	Pad Driver Alum Bearing Assembly with Shaft	1
E12978	Belt, BX39 V-Belt	1
E12979	Belt, BX47 V-Belt	1
E12981	Pulley BK60QT - 5.75 OD	1
E81064	Screw, 1/4"-20 x 0.750 Hex Head, Grade 5, Zinc	2
E81066	Washer, 3/8" Split Lock, Zinc	1
E81078	Washer, 1/4" Split Lock, Zinc	5
E83629	Screw, 3/8"-16 x 1.250 Hex Head, Grade 5, Zinc	1

Note: Not available for purchase assembled.

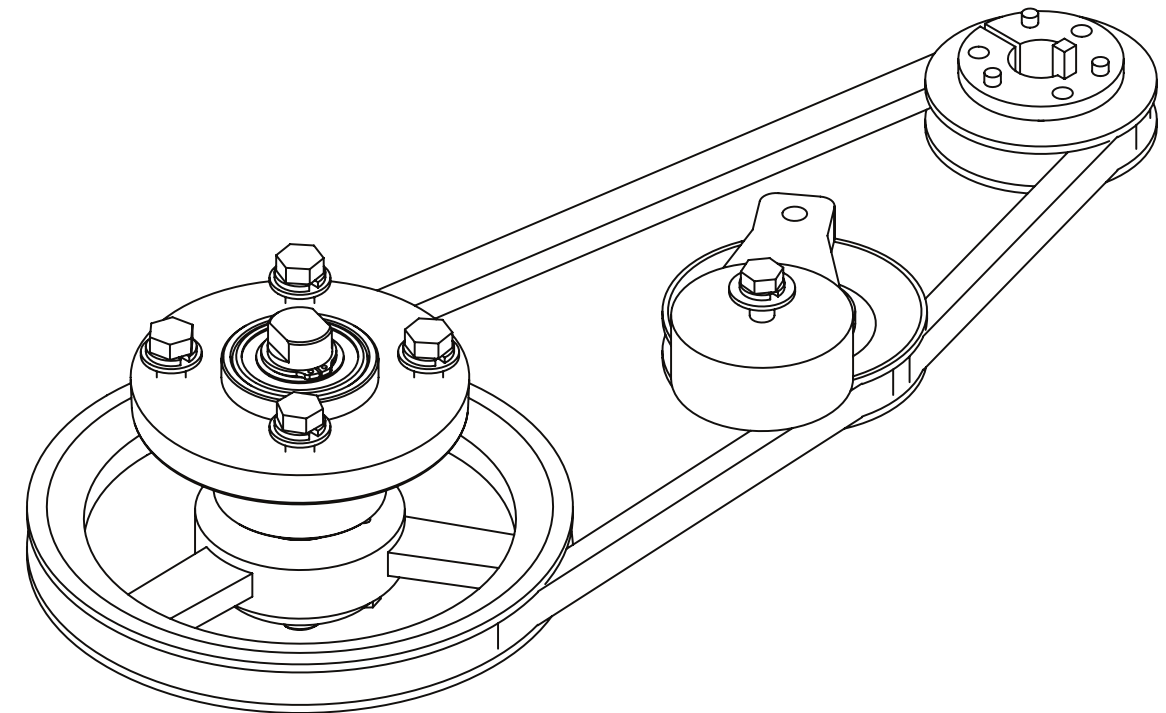

PAD DRIVE SYSTEM

EP50028 -- 21" Pad Drive Assembly
 EP50040 -- 27" Pad Drive Assembly

E10250 -- 21" Pad Driver
 E10252 -- 27" Pad Driver

Transport Pad

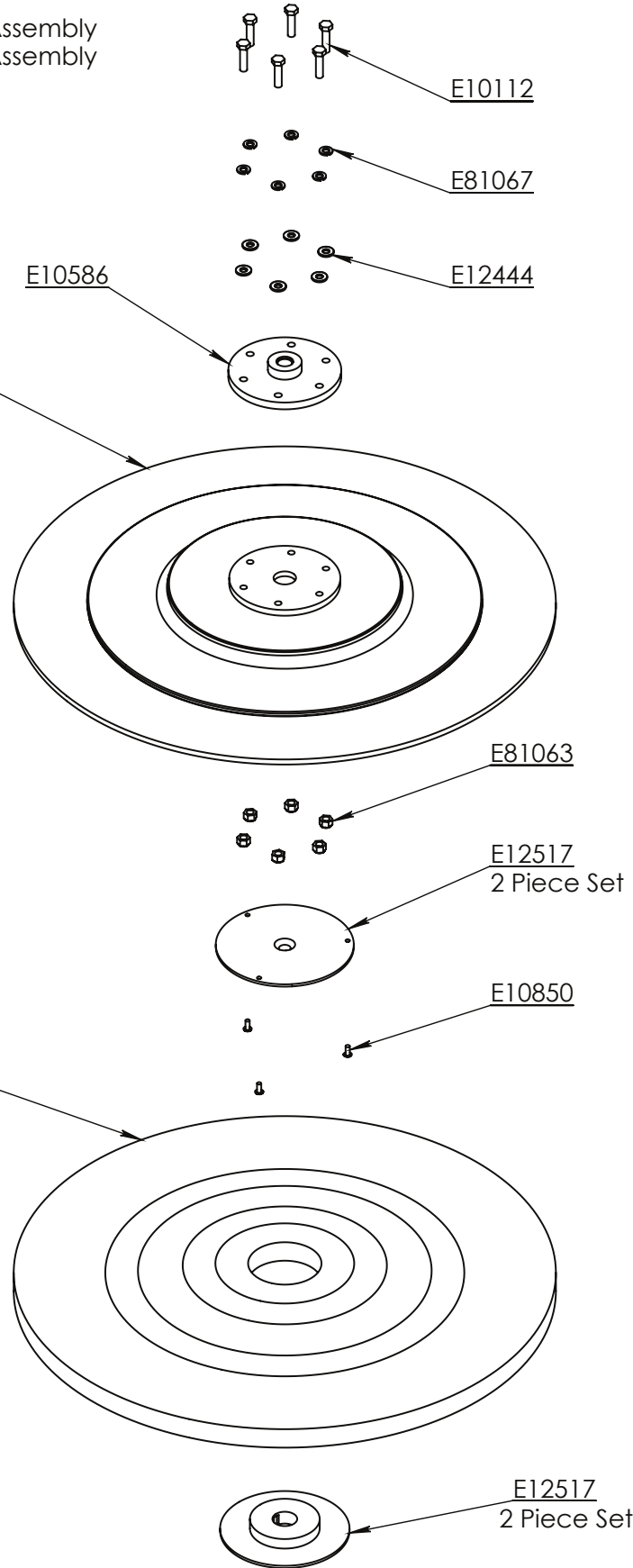

PART NUMBER	Description	QTY.
E10112	Screw, 5/16"-18 x 1.250 Hex Head Grade 5, Zinc	6
E10250	21" Pad Driver	1
E10252	27" Pad Driver	1
E10586	3/4" Pad Driver Shaft Coupling	1
E10850	Rivet, 3/16" OD x 15/16" L with 3/8" Head	3
E12444	Washer, 5/16" SAE, Zinc	6
E12517	Pad Lock, Center Lok II® RH Set Black	2
E81063	Nut, 5/16"-18, Nylon Lock, Grade 5, Zinc	6
E81067	Washer, 5/16" Split Lock, Zinc	6
EP50028	Pad Drive Assembly 21" Without Pad	1
EP50040	Pad Drive Assembly 27" Without Pad	1

NOTE: Pad driver assembly comes without pad.

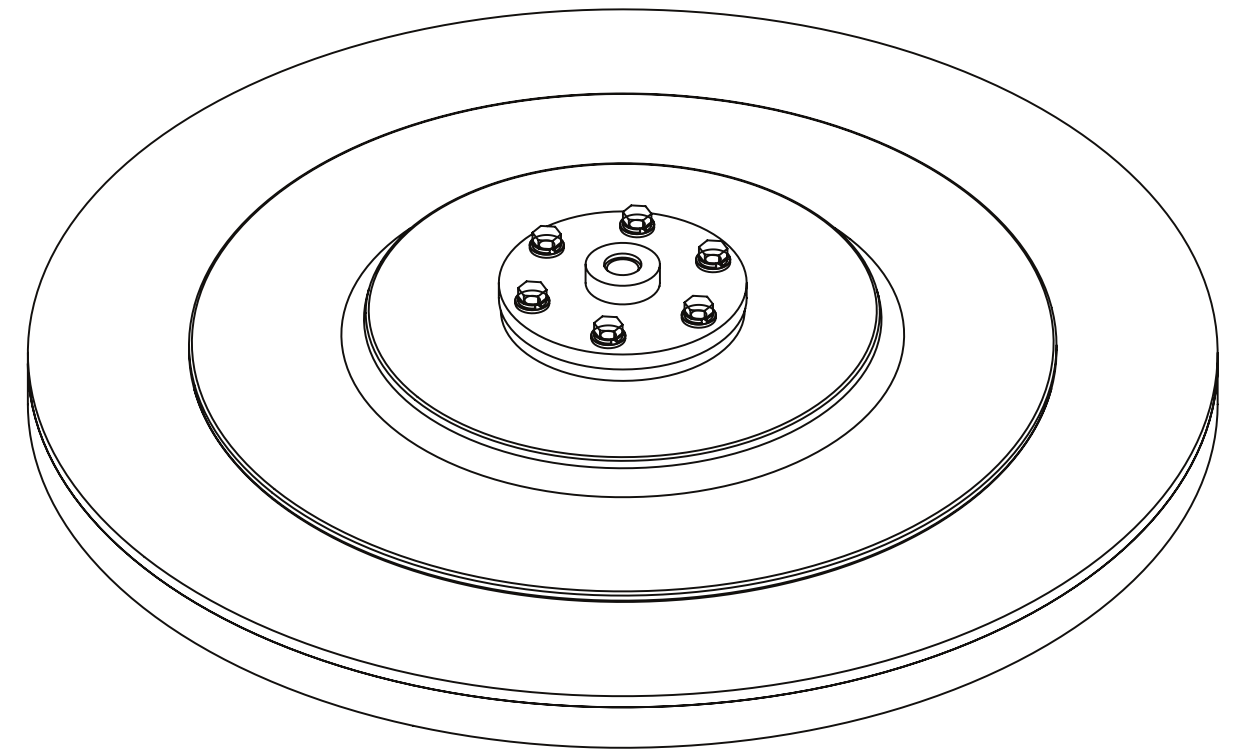

CENTRIFUGAL CLUTCH ASSEMBLY

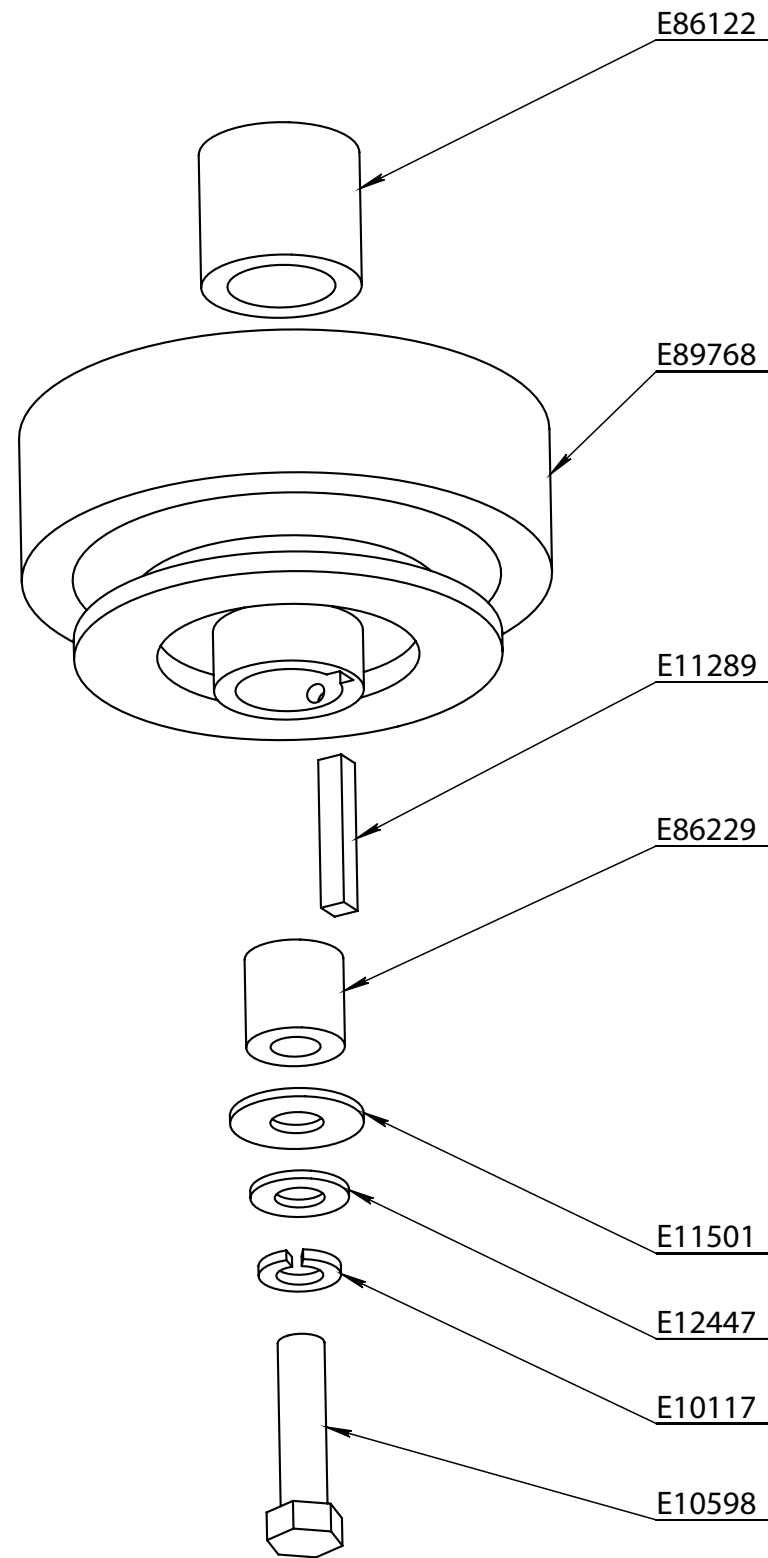

E86122 is installed to align the belt drive section of the clutch to the pad driver pulley belt drive section.

Remove and discard set screws from clutch before installing.

Install key after pushing clutch onto the engine drive shaft and aligning keyways.

Engine Idle RPM
1700-1780

E11501 should tighten onto the lip of the clutch. E86229 should be just inside the lip of the drive shaft hole.

PART NUMBER	Description	QTY.
E10117	Washer, 7/16" Split Lock, Zinc	1
E10598	Screw 7/16"-20 x 1.750 Hex Head, Grade 5, Zinc	1
E11289	Key 1/4" x 1/4" x 1.500"	1
E11501	Washer, 7/16" USS, Zinc	1
E89768	Clutch, Centrifugal 1750 RPM 4" Dia.	1
E12447	Washer, 7/16" SAE, Zinc	1
E86122	Spacer, Burnisher Kawasaki Clutch Top	1
E86229	Spacer, Burnisher Kawasaki Clutch Bottom	1

Note: Not available for purchase assembled.

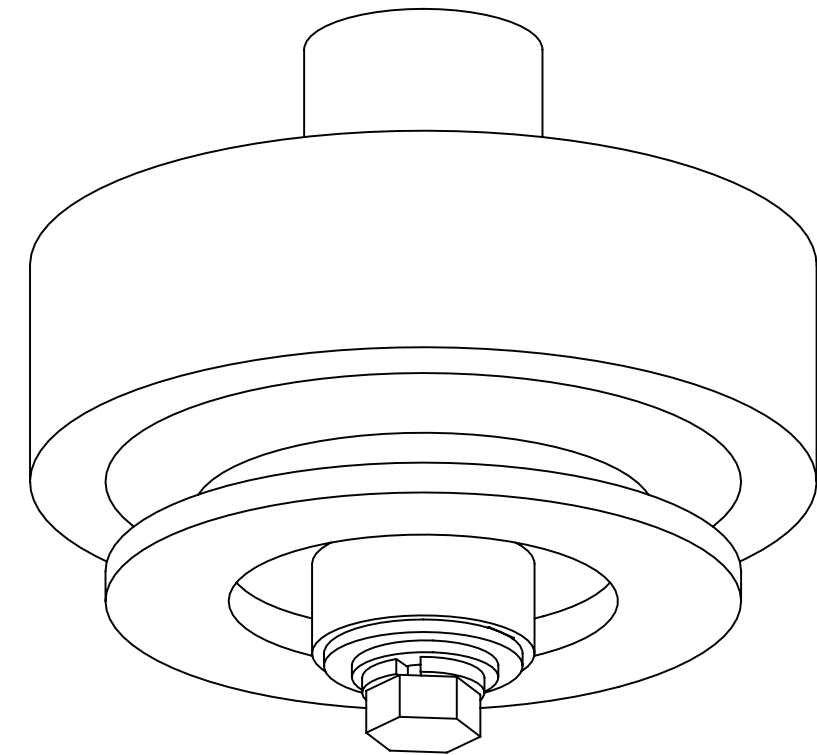

ELECTRICAL SCHEMATIC

E89585 - Wiring Harness

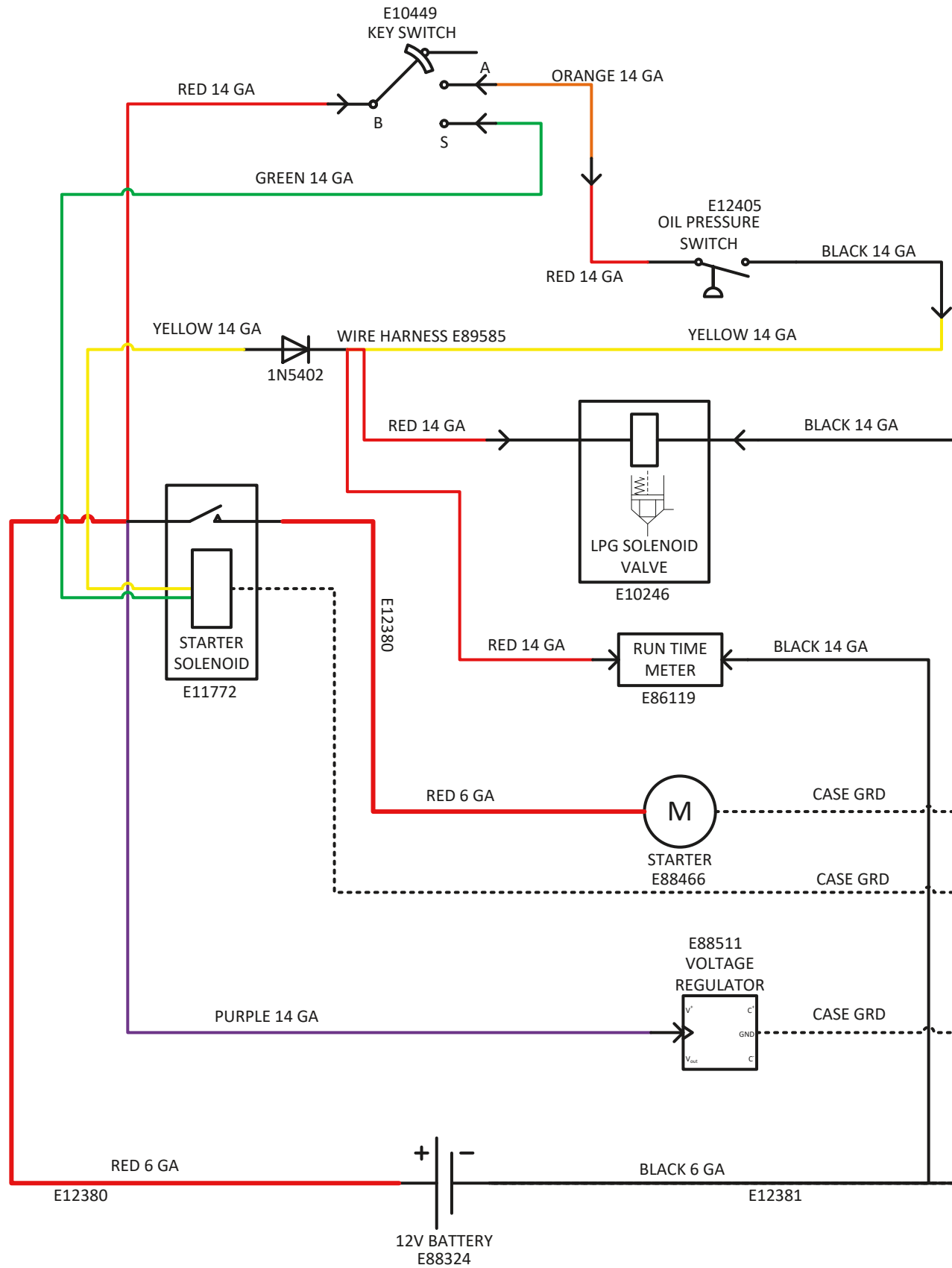

ELECTRICAL SCHEMATIC (emissions)

E89590 - Wiring Harness

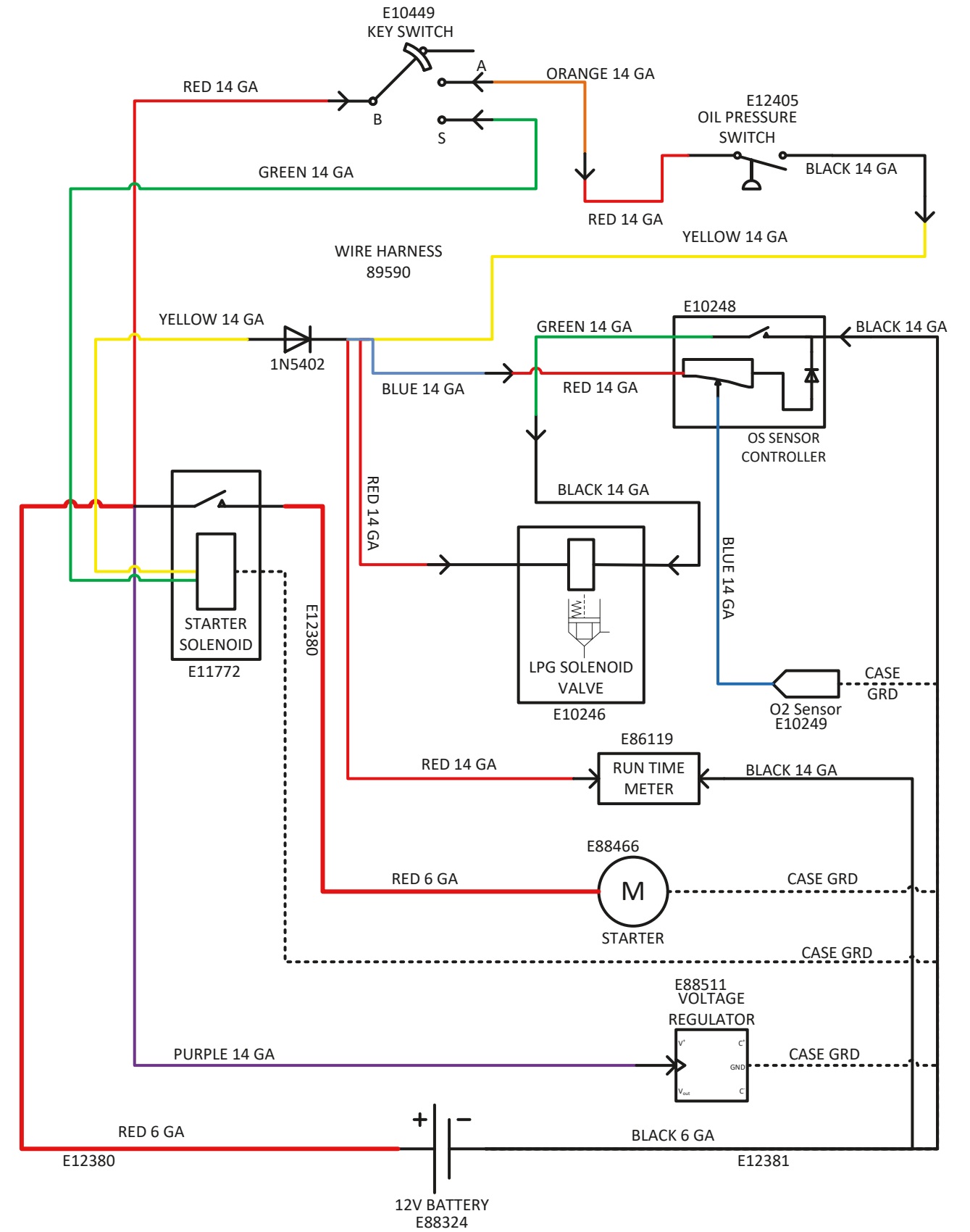

ENGINE MAINTENANCE KAWASAKI FS481V

PERIODIC MAINTENANCE PLEASE REFER TO ENGINE OWNERS MANUAL FOR MORE INFORMATION	DAILY	EVERY 100 HOURS	EVERY 200 HOURS
Check engine oil level and add if necessary	*		
Check and clean engine intake foam and intake paper filter	*		
Check and clean engine cooling air intake filter and replace if necessary (Part Number: E12360)	*		
General check for loose or lost nuts, screws, oil leakage, fuel hose connection, etc.	*		
Check belt tension	*		
Change engine oil (SAE 30 recommended) and Replace oil filter (Part Number: E88475)		*	
Clean dust and dirt from cylinder and cylinder head cooling fins		*	
Clean and regap sparkplugs (gap must be 0.030 in.)		*	
Replace air intake foam filter (Part Number: E88478)		*	
Replace air intake paper filter (Part Number: E88325)		*	
Replace spark plugs (Part Number: E88326)			*
Check and adjust valve clearance			*
Clean combustion chamber			*
Clean and lap valve seating surface			*

IMPORTANT NOTES:

- 1) Change engine oil and oil filter (Part Number: **E88475**) after first 8 hours of operation
- 2) Replace foam and paper air intake filters (Part Number: **E88478** & **E88325**) after first 25 hours of operation
- 3) Replace spark plugs (Part Number: **E88326**) after first 25 hours of operation
- 4) Maintenance should be done by qualified personnel only
- 5) Check and adjust valve clearance after initial 50 hours

TROUBLESHOOTING

PROBLEM	CAUSE	POSSIBLE SOLUTION
Engine will not turn over	Battery is dead	Recharge battery or replace if necessary
	Loose wire or bad connection	Check wires and connections
	Bad electrical component	Replace bad component
	Fuel system problem	Refer to engine owner's manual and read IMPORTANT below
Engine turns over, but will not start	Propane tank shut off valve in off position	Open propane tank shut off valve completely
	Low oil	Add oil
	Fuel system problem	Refer to engine owner's manual and read IMPORTANT below
	Propane tank empty	Fill propane tank
	Engine problem	Refer to engine owner's manual and read IMPORTANT below
Hard to start	Throttle lever in slow position	Push throttle lever to fast position
	Propane tank shut off valve not fully open	Open propane tank shut off valve completely
	Some type of engine problem	Refer to engine owner's manual and read IMPORTANT below
Engine stops suddenly and will not restart	Out of propane	Replace propane tank with full propane tank
	Low oil	Add oil
Engine overheats	Intake air filter is dirty	Remove air intake filter and clean
	Incorrect oil level	Add or remove oil to achieve proper oil level
Machine vibrates excessively	Pad not centered on pad driver	Remove pad and center pad properly on pad driver
	Pad damaged	Replace pad
	Loose bolts	Check and tighten bolts
	Pad center lock is loose	Tighten pad center lock securely
Machine is hard to push	Floor may be uneven in one spot	Try another spot on the floor
	Front end bearing housing not adjusted properly	Adjust the front end bearing housing
Machine pulls to the left	Floor may be uneven in one spot	Try another spot on the floor
	Front end bearing housing not adjusted properly	Adjust the front end bearing housing
Lacks power	Some type of engine problem	Refer to engine owner's manual and read IMPORTANT below
Engine stops and will restart, but stops again	Emission shut-down system engaged	Refer to engine owner's manual and read IMPORTANT below
Nothing here fixes the problem	Problem could have several causes	Read IMPORTANT below

IMPORTANT: Propane fueled combustion engines produce dangerous gases and must be serviced by authorized service personnel trained specifically to service propane fueled engines and fuel systems. The troubleshooting tips are not intended to take the place of authorized service personnel. If you are unsure of what to do contact an authorized service personnel. Before working on this machine you must be familiar with the safety instructions in this manual.

EMISSION CONTROL WARRANTY STATEMENT

YOUR WARRANTY RIGHTS AND OBLIGATIONS

The California Air Resource Board and Betco Corporation is pleased to explain the emissions control system warranty on your 2013 small off-road engine (SORE). In California and the other 49 States, new SORE must be designed, built and equipped to meet stringent anti-smog standards. Betco Corporation must warrant the emission control system on your SORE for the period of time listed below provided there has been no abuse, neglect or improper maintenance of your SORE.

Your emission control system may include parts such as the carburetor or fuel-injection system, the ignition system, and catalytic converter. Also included may be hoses, belts, connectors and other emission-related assemblies.

Where a warrantable condition exists, Betco Corporation will repair your SORE at no cost to you including diagnosis, parts and labor.

MANUFACTURER'S WARRANTY COVERAGE

The 1995 and later small off-road engines are warranted for two years. If any emission-related part on your engine is defective, the part will be repaired or replaced by Betco Corporation.

OWNER'S WARRANTY RESPONSIBILITIES

As the small off-road engine (SORE) owner, you are responsible for the performance of the required maintenance listed in your owner's manual. Betco Corporation recommends that you retain all receipts covering maintenance of your SORE engine, but Betco Corporation cannot deny warranty solely for the lack of receipts or for your failure to ensure the performance of all scheduled maintenance. As the SORE owner you should however be aware that Betco Corporation may deny your warranty if your SORE or its part has failed due to abuse, neglect, improper maintenance or unapproved modification.

You are responsible for presenting your SORE to a Betco Corporation distribution center as soon as the problem exists. The warranty repairs should be completed within a reasonable amount of time, not to exceed 30 days. If you have any questions regarding your warranty rights and responsibilities, you should contact Betco Corporation at 1-888-GO-BETCO (1-888-462-3826) or by email at warranty@betco.com.

Betco Corporation
400 Van Camp Road
Bowling Green, Ohio 43402
USA

GENERAL EMISSIONS WARRANTY COVERAGE

Betco Corporation warrants to the ultimate purchaser and each subsequent purchaser that the equipment is designed, built and equipped so as to conform with all applicable regulations; and free from defects in materials and workmanship that cause the failure of a warranted part to be identical in all material respects to that part as described in Betco Corporation's application for certification. The warranty period begins on the date the equipment is delivered to an ultimate purchaser or first placed into service. The warranty period is two years. Subject to certain conditions and exclusions as stated below, the warranty on emission-related parts is as follows:

1. Any warranted part that is not scheduled for replacement as required maintenance in the written instructions supplied, is warranted for the warranty period stated above. If the part fails during the period of warranty coverage, the part will be repaired or replaced by Betco Corporation according to subsection (4) below. Any such part repaired or replaced under warranty will be warranted for the remainder of the period.

EMISSION CONTROL WARRANTY STATEMENT

2. Any warranted part that is scheduled only for regular inspection in the written instructions supplied is warranted for the warranty period stated above. Any such part repaired or replaced under warranty will be warranted for the remaining warranty period.
3. Any warranted part that is scheduled for replacement as required maintenance in the written instructions supplied is warranted for the period of time before the first scheduled replacement date for that part. If the part fails before the first scheduled replacement, the part will be repaired or replaced by Betco Corporation according to subsection (4) below. Any such part repaired or replaced under warranty will be warranted for the remainder of the period prior to the first scheduled replacement point for the part.
4. Repair or replacement of any warranted part under the warranty provisions herein must be performed at a warranty station at no charge to the owner.
5. Notwithstanding the provisions herein, warranty services or repairs will be provided at all of our distribution centers that are franchised to service the subject engines or equipment.
6. The SORE owner will not be charged for diagnostic labor that is directly associated with diagnosis of a defective, emission-related warranted part, provided that such diagnostic work is performed at a warranty station.
7. Betco Corporation is not liable for damages to other engine or equipment components proximately caused by a failure under warranty of any warranted part.
8. Throughout the SORE warranty period stated above, Betco Corporation will maintain a supply of warranted parts sufficient to meet the expected demand for such parts.
9. Any replacement part may be used in the performance of any warranty maintenance or repairs and must be provided without charge to the owner. Such use will not reduce the warranty obligations of Betco Corporation.
10. Add-on or modified parts that are not exempted by the Air Resources Board may not be used. The use of any non-exempted add-on or modified parts by the ultimate purchaser will be grounds for disallowing a warranty claims. Betco Corporation will not be liable to warrant failures of warranted parts caused by the use of a non-exempted add-on or modified part.

WARRANTED PARTS

The repair or replacement of any warranted part otherwise eligible for warranty coverage may be excluded from such warranty coverage if Betco Corporation demonstrates that the SORE has been abused, neglected, or improperly maintained, and that such abuse, neglect, or improper maintenance was the direct cause of the need for repair or replacement of the part. That notwithstanding, any adjustment of a component that has a factory installed, and properly operating, adjustment limiting device is still eligible for warranty coverage. The following emission warranty parts are covered:

1. Fuel system: carburetor, pressure regulator, fuel lock off, and hoses
2. Ignition system: spark plug, ignition coil assembly, voltage regulator
3. Intake system: Intake system: intake manifold and air filter
4. Exhaust system: exhaust manifold and catalytic converter
5. Miscellaneous items used in above systems: hoses, connectors, and assemblies.

BETCO US WARRANTY POLICY

10 year coverage

Subject to the conditions stated below, Betco warrants parts and labor on rotationally molded polyethylene tanks/ housings and injection molded vacuum head assemblies to be free from defects in materials and workmanship for a period of ten years to the original purchaser.

3 Year Coverage

Subject to the conditions stated below, Betco warrants parts and labor on all other Betco components to be free from defects in materials and workmanship for a period of three years to the original purchaser.

- Lithium Ion battery for MotoMop™ is a full 3 years

1 Year Coverage

Subject to the conditions stated below, Betco offers a limited warranty on parts and labor on the following equipment: parts and accessories to be free from defects in materials and workmanship for a period of one year to the original purchaser.

- PowerUp™ 14 Upright Vacuum: #E29990-00
- Bac Pac Lite Vacuum: #85903-00
- FiberPRO® Floor Dryer: #85507-00
- WORKMAN™ Series Vacuums: #85024-00, #85025-00, #83012-00, #85027-00
- All Tools and Accessories
- All Battery Chargers
- Deep cycle batteries are pro-rated for 1 year

Allowable Travel Time Warranty Reimbursement:

Eligible equipment: All battery and propane powered equipment products. Warranty period: 90 days from date of sale to the original purchaser. A maximum 180 mile round trip at 50 cents per mile will be allowed for warranty consideration.

Propane Machine Warranty:

Kawasaki/Subaru engines are warranted by Kawasaki/Subaru for a period of 2 years against manufacturer defects. All other components (except wear items)* are warranted by Betco for a period of 3 years.

***Wear Items exempt from Warranty consideration include but may not be limited to: power cords, transport wheels, vacuum bags, belts, squeegee blades, pad drivers, clutch plates, handle grips, filters, screens, throttle cables, brushes and carbon brushes.**

Subject to the conditions and exceptions stated in this warranty, Betco warrants the Betco products to be free from defects in material and workmanship, under normal use and service, for the periods listed under the warranty policy to the original purchaser. At any time during the warranty period, Betco will furnish replacement parts for the Betco parts to the original purchaser. Such parts will be furnished and charged including transportation costs, to the original owner through any Betco authorized Service Distributor. If the original part is returned within the warranty policy period from date of delivery for inspection by Betco and is found to be defective the owner will be credited for the cost of replacement parts plus shipping and handling. Replacement parts that have become defective through wear or abuse are not included in this warranty.

This warranty does not apply to damage or defect caused by accident, misuse, Negligence, fire, or to any Betco product which has been serviced or repaired by other than an authorized Betco Service Distributor or Betco factory personnel. This warranty is void if products are used for any purpose other than that which was intended. There are no other warranties expressed or implied. In no event shall Betco be liable for incidental or consequential damages or any damage to person or property. (Please note some states do not allow the exclusion or limitations for incidental and consequential damages).

